



HGM7120N

HGM7110N/HGM7120N series power station automation controllers integrate digitization, intelligentization and network technology which are used for genset automation and monitor control system of single diesel unit to achieve remote start/stop, data measurement, alarm protection and etc. functions. It fit with LCD display, optional languages interface (Chinese, English and etc.), and it is reliable and easy to use.

Product Code : 6010092
Power Supply : DC(8-35)V
Case Dimensions : 209*116*45(mm)
Operating Temp. : (-25~+70)°C
Weight : 0.6kg

COMPLETE DESCRIPTION

GM7110N/HGM7120N series power station automation controllers integrate digitization, intelligentization and network technology which are used for genset automation and monitor control system of single diesel unit to achieve remote start/stop, data measurement, alarm protection and etc. functions. It fit with LCD display, optional languages interface (Chinese, English and etc.), and it is reliable and easy to use.

HGM7110N/HGM7120N series power station automation controllers adopt 32-bit micro-processor technology with precision parameters measuring, fixed value adjustment, time setting and set value adjusting and etc. Almost parameters can be configured from front panel of controller, and all parameters can be adjusted through PC software via USB/RS485 port and monitored through PC software via RS485. It can be widely used in all types of genset control automation system with compact structure, simple connections and high reliability.

PERFORMANCE AND CHARACTERISTICS

HGM7110N: ASM (Automatic Start Module), it controls generator to start/stop by remote signal;

HGM7120N: AMF (Auto Mains Failure), updates based on HGM7110N, especially suit for automatic system composed by generator and mains.

Main features as follows:

1. 32-bit ARM microcomputer has been used with higher level of hardware integration and stability.
2. 132x64 LCD with backlight and selectable language interface (Chinese, English, and other languages) that can be chosen on the spot. It is convenient for debugging personnel commissioning.
3. Hard-screen acrylic material been used to protect screen with great wear-resisting and scratch-resisting functions.
4. Silicone panel and pushbuttons can be used in extreme temperature environment.
5. RS485 communication interface enable "three remote functions" (remote control, remote measuring and remote communication) according to MODBUS protocol.
6. Suitable for 3-phase 4-wire, 3-phase 3-wire, single phase 2-wire, and 2-phase 3-wire systems with voltage 120/240V and frequency 50/60Hz;
7. Collects and shows 3-phase voltage, current, power parameter and frequency of generator or mains.

Mains

Line voltage (Uab, Ubc, and Uca)
Phase voltage (Ua, Ub, and Uc)
Frequency Hz
Phase sequence

Generator

Line voltage (Uab, Ubc, and Uca)
Phase voltage (Ua, Ub, and Uc)
Frequency Hz
Phase sequence

Load

Current Ia, Ib, Ic
Each phase and total active power P

A (unit)
kW (unit)

Reactive power Q	kvar (unit)
Apparent power S	kVA (unit)
Power factor	PF
Accumulate total generator power W	kWh (unit)
Output percentage with load	%

- For Mains, controller has over and under voltage, over and under frequency, loss of phase, and phase rotation detection functions; for generator, controller has over and under voltage, over and under frequency, over current and over power, reverse power, loss of phase, phase rotation detection functions.
- Precision collect parameters about Engine.

Temp. (WT)	°C/°F both be displayed
Oil Pressure (OP)	kPa/psi/bar all be displayed
Fuel Level (FL)	%(unit)
Speed (RPM)	r/min (RPM)
Voltage of Battery	V (unit)
Voltage of Charger	V (unit)
Total running accumulation maximum	65535 hours can be recorded.
Start times accumulation maximum	65535 times can be recorded

- Protection: automatic start/stop of the diesel gen-set, ATS (Auto Transfer Switch) control with perfect fault indication and protection function.
- With ETS (energize to stop), idle control, pre-heat control and rise/drop speed control functions, which are all relay outputs.
- Parameter setting: parameters can be modified and stored in internal FLASH memory and cannot be lost even in case of power outage; most of them can be adjusted using front panel of the controller and also can be modified using PC via RS485/ETHERNET port.
- Multiple temperatures, pressure, oil pressure sensor curves can be used and self-defined directly.
- Multiple crank disconnect conditions (speed, oil pressure, generator frequency) are optional.
- Widely power supply range DC(8~35)V, suitable to different starting battery voltage environment.
- Event log, real-time clock, scheduled start & stop generator (can be set as start genset once a day/week/month whether with load or not). Two gensets cycle start function.
- One minute before genset fault shutdown, controller can record data up to 5 pieces include mains voltage, mains frequency, generator voltage, generator frequency, current temperature, oil pressure, fuel level, speed and etc..
- It is used for pumping unit, moreover, can be indicating instrument as well (only indicate and alarm, relay without action).
- Maintenance function, maintenance time due can be user-defined (only warning/trip shutdown/alarm shutdown).
- Cycle start two gensets via RS485 (running time of both main unit and standby unit can be user defined)
- Waterproof security level IP65 due to rubber seal installed between the controller enclosure and panel foil.
- Controller uses metal fixing clips.
- Modular design, pluggable connection terminals and embedded installation way, and compact structure with easy mounting.

HGM7120n Typical Application

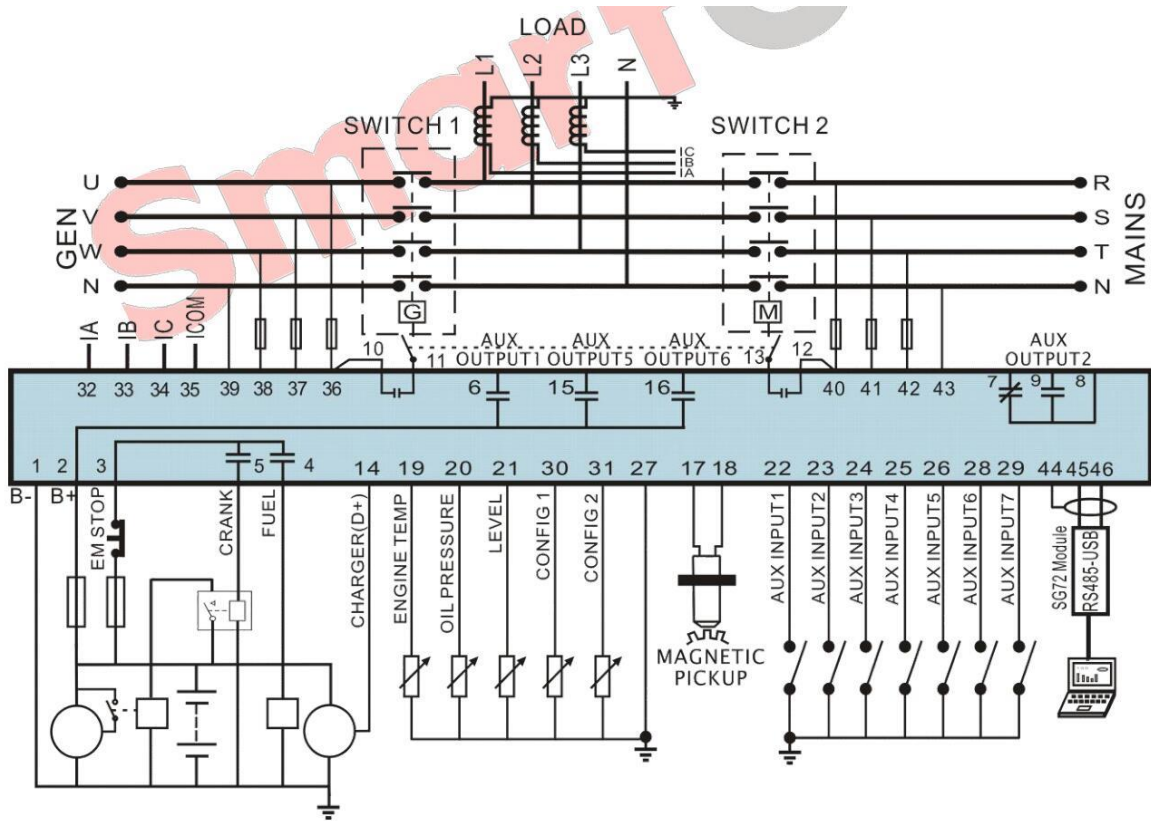

Figure 6 - HGM7120N Typical Application